

REFLECT PERFECTION

DV1 Clearcoat Spray Gun

EXPERIENCE THE NEXT GENERATION OF CLEARCOAT APPLICATION

Introducing the DV1 Clearcoat Spray Gun: the latest addition to the DV1 family of revolutionary spray guns. This gun provides consistency and optimization in spraying the leading clearcoats in the market today.

The DV1 Clearcoat gun features the all-new DV1-C1 PLUS Clearcoat Air Cap, delivering superior high-efficiency performance for a flawless finish. This air cap distributes even, super-fine particles in a consistent, homogenous pattern to lay the clear flat, allowing painters to easily wet up a surface while minimizing runs and sags on vertical panels. The all-new fluid tip design increases fluid flow while stabilizing air flow, minimizing material usage and providing significant paint savings.

With a new black matte finish, the DV1 Clearcoat boasts a better grip for easy handling, ensuring maximum comfort on the job, while providing more power for higher productivity.

Through faster performance, proven paint savings and superior atomization, the DV1 Clearcoat spray gun gives painters the confidence to know that they can achieve a high-quality, glass-like finish every time.

FEATURES

- Delivers ultimate clearcoat application performance
- Sprays a uniform pattern that lays the clear flat and easily wets up a surface
- Atomizes effortlessly, producing an even distribution of super-fine particles
- Provides maximum comfort and easy use from set-up through the entire spraying process
- Provides improved transfer efficiency and saves time completing each job



DV1 CLEARCOAT SPRAY GUN SYSTEM COMPONENTS & ORDER NUMBERS

Part Listing

Image Reference	Part Number	Description	Quantity
1	-	Retaining Ring	1
2	-	Slip Ring	1
3	-	Retaining Ring Seal	1
4	704425	Retaining Ring Sub Assembly	1
5	-	Air Cap	1
6	191972	Spring Clip (Kit of 10)	1
7	See Table 1	Air Cap & Retaining Ring	1
8	See Table 2	Fluid Tip	1
9	704402	Deflector Plate	1
10+	704403	Screw (Kit of 3)	3
11	-	Sprayhead	1
12+	704401	Gasket (Kit of 2)	1
13	704436	Spray Head Kit	1
14	-	Needle Packing	1
15	-	Packing Spring	1
16	-	Packing Nut	1
17+	702731	Packing, Spring & Packing Nut Kit	1
18	-	O Ring	1
19	-	Air Valve Cage	1
20	-	Seal	2
21	-	Seal Guide	2
22	-	Valve Seat	1
23#	704422	Front Cage Assembly	1
24	-	Air Valve Stem	1
25#	-	Air Valve Spring	1
26	-	Rear Seal Housing	1
27	704423	Rear Seal Assembly	1
28+	704424	Air Valve Assembly	1
29	-	Identification Sleeve	1
30	-	Sleeve Nut	1
31	704437	Sleeve Kit	1
32	See Table 2	Fluid Needle	1
33	-	Needle Spring	1
34	-	Spring Pad	1
35#+	704405	Needle Spring Kit	1
36	704404	Fluid Adjusting Knob	1
37	-	O Ring	2
38	-	Flow Valve Body	1
39	-	Flow Valve Knob	1
40	-	Circlip	1
41	704417	Inline Flow Valve	1
42	-	Plug	1
43	-	Trigger Screw	1
44	-	Spring	1
45	-	Trigger Stud	1
46	-	Trigger	1
47	704406	Trigger, Stud, Spring & Screw Kit	1
48	-	Screw	1
49	-	Spreader Valve Pin	1
50	-	Spreader Valve Stem	1
51#+	-	O Ring	1
52	-	Valve Body	1
53#+	-	O Ring	1
54	-	Spreader Valve Adjusting Knob	1
55	704419	Spreader Knob Kit (Not for use with digital gauge)	1
56	704418	Spreader Valve Assembly	1
57	-	Valve Tool	1
58	-	Torx Driver	1
59	-	Tip Wrench	1
60	704429	Tool Kit	1
61*	GFC-501	Gravity Cup Plastic (Shown)	1
	702576	Gravity Cup Aluminum	1

Gauges

62	704426	Atex Approved (EU)	Digital Pressure Gauge
	704427	FM Approved (USA, Canada)	Digital Pressure Gauge

Service Kits

	704430	Minor Service Kit	Includes Items Marked #
	704431	Major Service Kit	Includes Items Marked +

*Cup not included in North America kit

Table 1: Performance Guide

Air Cap Part Number	704434
Air Cap & Type	DV1-C1 Plus (HVLPL)
Recommended Air Pressure at Digital Gauge	1.5 bar (22 psi)
Air Consumption	285 L/min (10.0 scfm)
Fluid Flow	140 - 190 g/min
Pattern Height	325 mm (12.8 in)

Table 2: Tips & Needles

Fluid Tip			Needle	
Part Number	Size	Marking	Part Number	Marking
704440	1.0	DV1-1.0 C	704416	DV1-300
704441	1.1	DV1-1.1 C		
704442	1.2	DV1-1.2 C		
704443	1.3	DV1-1.3 C		
704444	1.4	DV1-1.4 C		

Spray Gun Kit

Order Number	Description	Air Cap	Gauged	Needle	Cup Type
704520	DV1 Clearcoat C1 Plus Gauged	DV1-C1 Plus	Dgi Pro Pod	1.2, 1.3, 1.4	Uncupped, Includes DPC Adapter

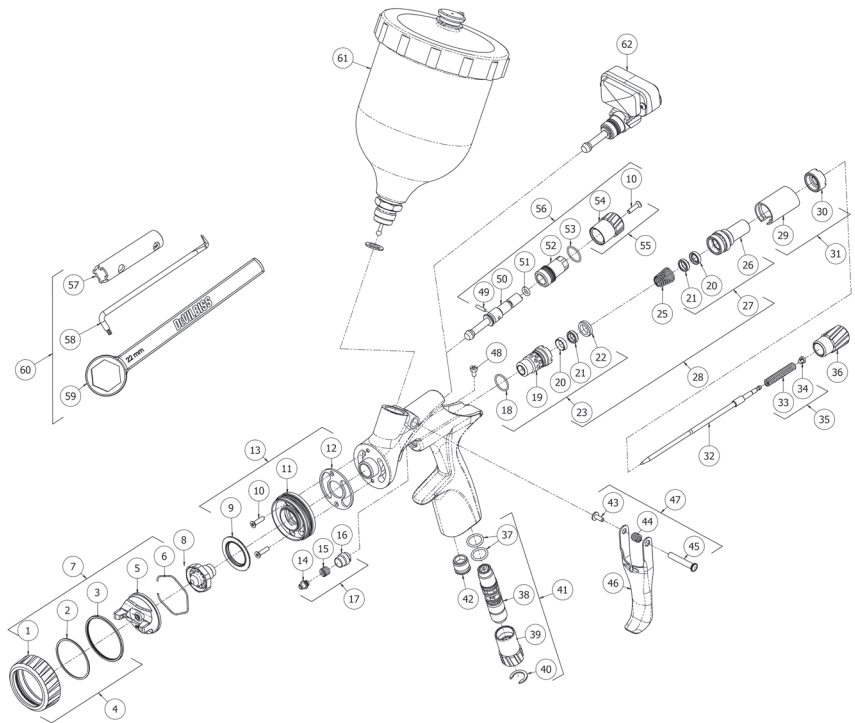

DeVilbiss Automotive Refinishing

1-800-445-3988 | askus@carlisleleft.com | autorefinishdevilbiss.com

devilbissdv1.com



1-800-992-4657 | askcft@carlisleleft.com | carlisleleft.com

©2019 Carlisle Fluid Technologies, Inc. DeVilbiss is a registered trademark of Carlisle Fluid Technologies, Inc. Models and specifications subject to change without notice. All rights reserved. | 19CFT467